

DEPENDABILITY ADAPTABILITY
RELIABILITY DURABILITY



As a leading manufacturer of enclosures and illuminated street name, blank out and lane control signs in the U.S., Southern Manufacturing has a history of quality and reliability that dates back to 1938.

Utilizing a clear vision for traffic safety, Southern Manufacturing is dedicated to improving technology and fabrication. At the same time we are keeping the highest standards of quality, reliability and low cost of operation for our customers. Southern's depth of engineering and manufacturing turn today's challenges into tomorrow's realities

Illuminated Street Name



Southern Manufacturing, with an installed base of over 10,000 signs nationwide, is proud to be recognized as the leading manufacturer of internally illuminated street name signs. Southern's unwavering dedication to continuous improvements in design and technology has led to the creation of products that excel in ease of maintenance, durability, and customer responsive design.

Because lenses, light engines, and power supplies can normally be replaced without sign removal, Southern's signs are easy to maintain. Southern's signs are also durable. Designed to meet the most rigid hurricane standards, all Southern Manufacturing signs are UL listed, a standard that reflects our long-standing commitment to providing consistent high quality products. Illuminated street name signs also carry a six year limited warranty, are available in both LED and fluorescent configurations, and can be installed as either free swinging signs or rigid mounted. They are available in 4 foot, 6 foot and 8 foot lengths and either single faced or double faced styles.

In response to communities' demand for customized signs, Southern's advanced sign CAD systems can produce the most demanding logos, and Southern's powder coated housings can be painted to complement the streetscape of any city. Southern's illuminated street name signs are constructed of the highest quality materials from the 5052 H32 .125" gauge aluminum bodies to the Lexan, electrical components, and 3M highway films. The sign bodies are continuously welded for superior strength and weather protection.

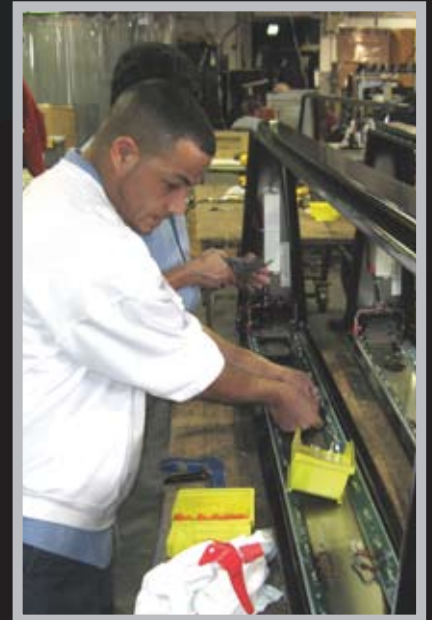

Southern Manufacturing
501 Herndon Avenue
Orlando, FL 32803
Ph: 407-894-8851
1-800-866-5699
contactus@southernmfg.com



Illuminated Street Signs

STANDARD

Designed for maximum illumination and easy maintenance. Available in single or double face, LED or fluorescent.

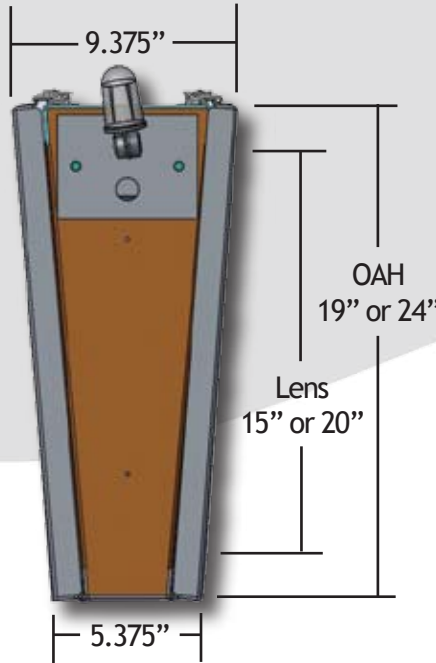

THIN LED

All of the advantages of our standard LED, but a slimmer frame. Rigid or swinging mount. 19 inch only.

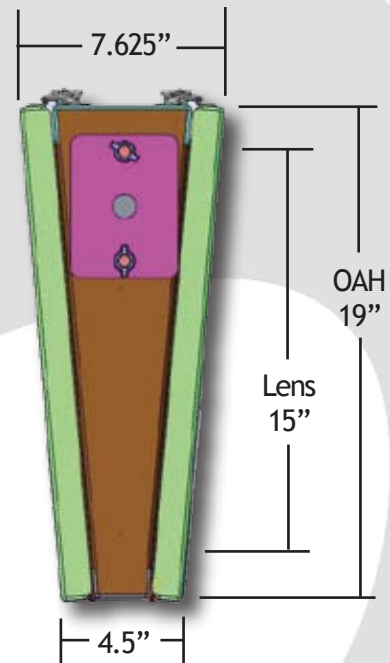

Features:

- Excellent day and night visibility
- Energy efficient/Very Low wattage required for LED
- Standard design requires no tools to open sign or replace lens.
- Designed to withstand 110 mph wind.
- Radiant high temperature fail-safe circuit for LED to prevent premature burn out in extreme temperatures.
- UL listed.
- Mounting brackets - tri-stud on top of sign and back rigid mount available.
- 6 year limited warranty

Weight in Pounds of Double Faced Signs

	4 x 19	6 x 19	8 x 19	4 x 24	6 x 24	8 x 24
Standard	45	64	83	48	69	90
Thin LED	42	60	79	N/A	N/A	N/A
Fluorescent	55	74	94	58	79	101

AC Load in Watts

	4' SF	6" SF	8' SF	4' DF	6' DF	8' DF
Standard	21	28	36	36	51	66
Thin LED	21	28	36	36	51	66
Fluorescent	143	143	143	143	143	143

Southern Manufacturing • 501 Herndon Avenue • Orlando, FL 32803
 PH: 407-894-8851 • 1-800-866-5699
contactus@southernmfg.com